



ROTEADOR
AC1200 GIGABIT
FY-R12G

Anatel 05093-24-16680

Dual Band Wi-Fi 5 Router

1 Produto



introdução

O FY-R12G suporta o protocolo IEEE 802.11ac (Wi-Fi5) e é um roteador sem fio de banda dupla totalmente gigabit. O design de aparência do produto adota o design tradicional de quatro antenas horizontais e combina com os elementos de design do carro de corrida. A aparência é linda e generosa

- 1) Configuração de hardware: plataforma de chip Realtek WIFI5 RTL8197FH;
- 2) Forma do produto: 1 interface WAN, 3 interfaces LAN, todas com suporte para adaptação 1000/100/10;
- 3) A taxa de conexão máxima sem fio de 2,4 GHz é de 300 Mbps, a taxa de conexão máxima de 5 GHz é de 867 Mbps e a taxa de conexão total é de 1167 Mbps;

2 Product specifications

2.1 Product configuration table

Hardware indicators	Model	FY-R12G
	Product Name	Gigabit Dual Band Wi-Fi 5 Router
	CPU	RTL8197FH
	2.4G Chip	RTL8197H Inside

5G Chip	RTL8812
Wireless Protocol	Support 802.11 b/g/n/a/ac
RAM	64MB
ROM	8MB
PA\LNA	2.4G IPA , 5G IPA
Modulation	DBPSK/DQPSK/CCK/BPSK/QPSK/16QAM/64QAM/256QAM
OFDMA	Support
MU-MIMO	Support
TWT	Support
Bandwidth	2.4G HT40 5G HT80
LED	Red/Green
Ethernet	WAN 1GE LAN 3GE
Antenna	2.4G Gain 5dBi 2 External 5G Gain 5dBi 2 External
Operating bandwidth	HT20\HT40\HT80
Power specifications	12V 1.0A
Power consumption	<12W

2.2 Buttons and interfaces



- WAN interfaces: 1, supporting 1000/100/10Mbps adaption
- LAN interfaces: 1, supporting 1000/100/10Mbps adaption
- Button specifications: 1 reset/WPS button
- Power interface specification: 12V 1.0A, diameter 6.3mm, inner needle round head 2.1mm

2.3 LED

Red	OFF	Indicates that the power is not on (the green light is off at the same time) or the network is normal
	Blink	Indicates that MESH networking failed
	ON	Indicates that the Internet is unavailable
Green	OFF	Indicates that the power is not on (the red light is off at the same time) or the Internet is unavailable
	Blink	Indicates that WPS code pairing is in progress
	ON	Indicates that the Internet is used normally

2.4 Block diagram

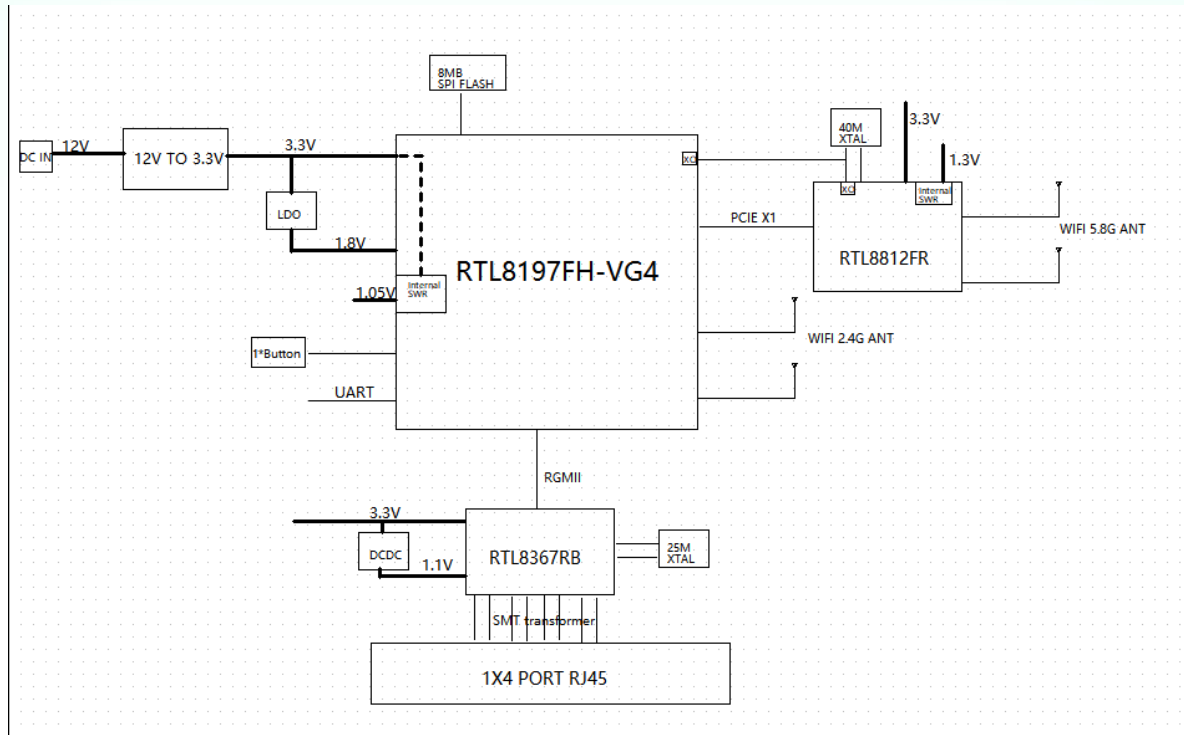

3 Wi-Fi Specifications

2.4GHz (802.11n, 2*2)	
Standards	IEEE802.11n/IEEE802.11g/EEE 802.11b
TX. Power	MCS7: 21dbm
RSSI	MCS7: -75dbm
Antenna	Two (2) external 5dBi antennas
Connection rate	300Mbps
5GHz (802.11ac,2*2)	
Standards	5.0GHz: 802.11ac/IEEE 802.11n/IEEE 802.11a
TX. Power	MCS9: 19dbm
	MCS9: -64dbm
RSSI	MCS9: -61dBm
	MCS11: -54dBm
Antenna	Two (2) external 5dBi antennas
Connection rate	867Mbps

4 Feature

Function	describe	Degree of support
Network Protocol	802.1q/1p VLAN over RFC2684 bridge encapsulation	Support
	PPPoE	Support
	PPPoE passthrough	Support
	PPPoE filtering of non-PPPoE packets between WAN and LAN	Support
	Auto clean up of remote stalled PPP sessions at BRAS	Support
	IpoE	Support
	Transparent bridging between all LAN and WAN interfaces	Support
	WAN to WAN blocking in bridgemode	Support
	Ethernet as WAN	Support
network	Full Cone NAT	Support
	DMZ Host	Support
ALG	FTP	Support
	TFTP	Support
	SIP	Support
	RTSP	Support
	H.323	Support
	Port Triggering	Support
	PPTP	Support
	IPSec/VPN and IPSec/L2TP	Support
VPN	IPSec	Support
	L2TP	Support
	PPTP	Support
Firewall/Filtering	Status	Support
	DoS	Support
	packet filtering	Support
	LAN Side firewall	Support
Parental control	Time of day usage restriction	Support
	URI/URL Filtering	Support
QoS	IP/Bridge/802.1p	Support
	Rate Control on upstream traffic	Support
	Support SP, WRR,WFQ priority VLAN stacking (Q-in-Q)	Support
Router	RIP v1/v2	Support
	Policy Routing	Support
IGMP	Proxy and snooping	Support
	IGMP v2 and v3	Support
	Support for IPv6	Support
IPv6	IPv6 Ready Logo Certified	Support
	IPv6 Firewall	Support

	IPv6 capable apps	Support
FS	SquashFS	Support
	JFFS2	Support
	tmpfs	Support
	VFAT	Support
	NTFS	Support
DHCP server	Support for multiple subnets	Support
	Static IP lease	Support
	DHCP relay	Support
DHCP Client	DHCP client	Support
Variable IP	Second IP address on LAN interface	Support
DNS agent	Built in DNS server	Support
	Caching previous requests	Support
GUI	WEBUI	Support
TR-069 协议	Digest Authentication, SSL and Basic Authentication, SSL and Digest Authentication	Support
	Auto-launch and exit-on-idle	Support
	TR-098	Support
	TR-098 profile support	Support
	TR-111 (part 1)	Support
	TR-140	Support
UPnP	TR-104	Support
	Internet Gateway Device (IGDv1.0)	Support
Security	Finite(24 hour) duration of virtual server entries created using UPnP	Support
	Service access based on incoming interface and/or source IP address	Support
Log	Automatic logout from CLI after inactivity	Support
	Log	Support
Diagnostic	Ping	Support
	Tracert	Support
Wireless	Support MCS 0-15 and MCS 32 modulation and coding rates	Support
	Support 20M and 40M channels	Support
	Support for STBC in both TX and RX	Support
	WEP encryption	Support
	WPA/WPA2	Support
	WPA-PSK/WPA2-PSK	Support
	Mac Filter base on each SSID	Support
	Multiple SSID	Support
	Support SSID hidden	Support
	SSID User Isolation	Support
	WPS	Support
	Enable or disable WIFI through GUI	Support
	bandsteering	Support
Others	Dynamic DNS	Support

	sntp time synchronization	Support
	ssh	Support
	telnet	Support
	Power Management	Support

5 Environment

- Operating temperature: 0°C ~ 40°C
- Operating humidity: 10% ~ 90% RH
- Storage temperature: -10°C ~ 70°C
- Storage humidity: 5% ~ 95% RH